

DYNAMICAL MODELLING AND MODEL ANALYSIS IN NEUROENDOCRINOLOGY



Theses of the Ph.D. Dissertation

Dávid Csércsik

Supervisor:
Gábor Szederkényi, Ph.D.

Scientific advisor:
Katalin Hangos, D.Sc.

Péter Pázmány Catholic University
Faculty of Information Technology

Budapest, 2010

1 Motivation and aim

Systems biology [1] is an emerging interdisciplinary branch of science that aims to study and computationally describe the interactions and interaction networks in biological systems. The models resulting from this approach can be used to explain dynamical mechanisms and phenomena, and for gaining predictions corresponding to the behavior of the system of interest. One of the most important and interesting known complex biological systems is the female reproductive neuroendocrine system, where the buzzword *complex* [2, 3] corresponds not only to the number of interacting elements and the number of interactions, but also to the wide range of time scales involved in the processes.

Dynamical models, which represent essential tools of the methodology of systems biology, have been already used to describe dynamical phenomena in neuroendocrinology, eg. mating-induced prolactin rhythm [4], dopamine synthesis and release [5] or membrane dynamics of magnocellular neurosecretory cells [6].

During my research I focused on two interesting fields of neuroendocrine modelling [7] and model analysis, where new biological results of the recent decade opened the way for the possibility of mathematical description and engineering analysis of new dynamical paradigms. Regarding the synthesis, identification and analysis of the applied models, in addition to the systems biology approach, engineering principles and methods are used in this interdisciplinary field.

The first topic of interest was the dynamical description of convergent signaling pathways corresponding to rapid (G-protein coupled) and slow (β -arrestin coupled) transmission [8, 9].

Until the 2000s the most accepted classic paradigm of signaling, related to G protein coupled receptors, has been that the significantly important elements which contribute to information transfer into the internal system of the cell are the α and $\beta\gamma$ subunits of G proteins (see the review [10]). In recent years it has been shown that β -Arrestins not only take part in receptor desensitization [11], and attenuation of G protein coupled signaling, but they do form an endocytic protein complex, which initiates a G protein independent transmission and regulation of ERK [12, 13, 8, 14, 9], an important kinase, playing central role in the intracellular signaling network (ERK is also activated by G protein coupled pathways). The recognition, that a single receptor acts as multiple source of signaling pathways and various drugs bind to this receptor, might influence each of this pathways (in contrast to

pathway-specific drugs like Lithium in the case of dopamine signaling [15]), led to the reassessment of the efficacy concept [16].

These recent biological findings opened a way for constructing dynamical models [7], which are able to describe the interaction of the two convergent, but qualitatively different signaling mechanisms. Thesis 1 deals with this topic. The proposed model is constructed in strict reaction kinetic form (governed by the mass action law), in order to stay in a model class for which the deficiency-based multistability-related results of Feinberg et al. [17, 18, 19] can be applied.

The second field of interest, which is aimed in my work, is the electrophysiological modelling of Gonadotropin-releasing hormone (GnRH) neurons. GnRH is secreted in the hypothalamus in a pulsatile way [20], with interpulse intervals varying on the scale of 8-240 minutes. The anterior pituitary, in response to GnRH, secretes hormones as well in a pulsatile way to stimulate the growth and development of ovarian follicles: Follicle-stimulating hormone (FSH) and luteinizing hormone (LH). In addition to some other regulation mechanisms, the ovarian hormones feed back to the hypothalamus and also to the pituitary. Via the multiple feedback loops connecting these endocrine and neuroendocrine tissues, the system of hypothalamic, ovarian and pituitary hormones regulates and maintains the menstrual cycle in adult women.

With the application of cell marking based on the green fluorescent protein (GFP) and transgenic mice, the targeted measurements and electrophysiological experiments on GnRH neurons became available [21, 22]. Based on such electrophysiological data recorded from GnRH neurons, the mathematical description of the electrophysiology of this important cell became possible.

Furthermore, while the application of the Hodgkin-Huxley model class is widespread and dominant in the literature of computational neuroscience, and several papers have been published about the parameter estimation of such models, there is a lack of articles in the literature, which aim the analysis of the identifiability properties of this important system class. Theses 2 and 3 of my work are related to the questions of identifiability and parameter estimation of neuronal models.

2 Materials and Methods

Dynamical systems [23], described by the mathematical apparatus of nonlinear ordinary differential equations (ODEs), are widely used for the description of models in the field of systems biology and computational neuroscience [24]. This work is also based on the application and analysis of such ODE models.

2.1 Reaction kinetic systems with mass action law kinetics

As mentioned before, the model corresponding to Thesis 1, which describes G protein dependent and independent signaling, belongs to the class of reaction kinetic systems. In the case of reaction kinetic models, we consider a system of n chemical species participating in an r reversible steps reaction network **in a closed system under isothermal and isobaric conditions**:

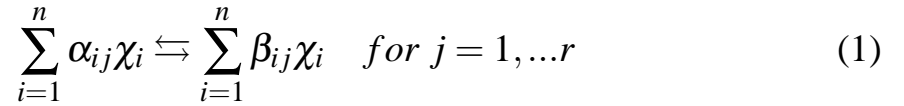

where the integers $\alpha_{ij}, \beta_{ij} \in \mathbb{N}$ are the stoichiometric coefficients for specie χ_i in the reaction step j . The r stoichiometric vectors are defined as $v_{ij} = \beta_{ij} - \alpha_{ij}$. The reaction rate in each reversible step is assumed to obey the Mass Action Law [17]:

$$W_j = k_j^+ \prod_{i=1}^n x_i^{\alpha_{ij}} - k_j^- \prod_{i=1}^n x_i^{\beta_{ij}} \quad (2)$$

where k_j^+ and k_j^- are the constants of the direct and of the inverse reaction rates of the j -th reaction step. The concentration vector of species is represented by x where the component $x_i \geq 0$ is the concentration of the specie χ_i .

Reaction kinetics equations that describe the evolution of the states in time can be expressed in matrix notation:

$$\dot{x} = \mathcal{N} \cdot W \quad (3)$$

where $\mathcal{N} \in \mathbb{R}^{n \times r}$ and $W \in \mathbb{R}^{r \times 1}$ are the matrices of stoichiometric vectors and the vector of reaction rates, respectively.

The linear combination of species defined by the stoichiometric vectors are called complexes.

Reaction schemes

For graphical representation of the kinetic system, *reaction schemes* can be used, which describe the structure of the enzymatic and non-enzymatic reactions in a compressed way (not depicting every single reaction). Reaction schemes can be depicted using **hypergraphs** in mathematical terms, where the edges may be adjacent to more than two vertices. The vertices of a reaction scheme correspond to the non enzymatic complex type components, while the hyper-edges describe chemical reactions (not necessarily reaction steps!). An enzyme-catalytic reaction corresponds to a pair of hyper-edges with different directions both adjacent to three components S, P and E (being the substrate, product and enzyme, respectively). The reaction scheme of the model presented in Thesis 1 can be found in Figure 1 (see section 3).

2.2 Hodgkin-Huxley type mathematical modeling of membrane dynamics and ion channels

Hodgkin-Huxley (HH) models, which stand for the most widely used model class in computational neuroscience, are nonlinear electric circuit models, composed of parallel voltage dependent (and possibly voltage independent) conductances, which refer to various type membrane currents.

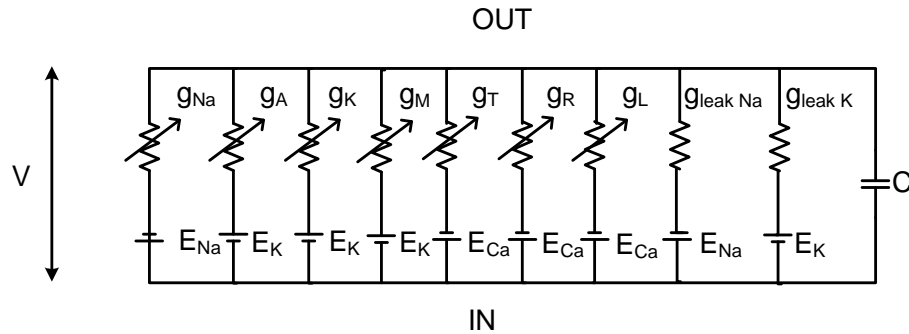

Figure 1: Parallel conductance model of the GnRH neuron (described in Thesis 3), with conductances representing different ion channels in voltage dependent and independent manner. g_{Na} denotes the sodium conductance, g_A , g_K and g_M denote the A-type, delayed rectifier and M-type potassium conductances, g_T , g_R and g_L stand for the conductances related to T-type low voltage activated and the R and L-type high voltage activated calcium currents, g_{leakNa} and g_{leakK} correspond to the voltage independent leakage currents.

The general HH model is based on the description of ionic currents in the following form:

$$I_i = g_i m_i^{p_{mi}} h_i^{p_{hi}} (V - E_i) \quad (4)$$

where I_i is the current of the i -th channel, m_i and h_i are the corresponding activation and inactivation variables on the powers p_{mi} and p_{hi} , which correspond to the number of independent subunits of the voltage channel protein. V is the membrane voltage and E_i is the reversal potential of the corresponding ion.

The dynamics of the activation and inactivation variables are described by

$$\frac{dm_i}{dt} = (m_{i\infty}(V) - m_i)/\tau_{mi}(V), \quad \frac{dh_i}{dt} = (h_{i\infty}(V) - h_i)/\tau_{hi}(V) \quad (5)$$

where $m_{i\infty}(V)$ and $h_{i\infty}(V)$ denote the voltage dependent steady state values of activation and inactivation variables, and $\tau_{mi}(V)$ and $\tau_{hi}(V)$ denote the voltage dependent time constants.

The voltage dependence of the steady state activation/inactivation functions is usually described by Boltzmann-functions in the form of

$$\left(1 + \exp\left(\frac{V_{1/2} - V}{k}\right)\right)^{-1}$$

where the parameters $V_{1/2}$, k can be different regarding the activation/inactivation variable of the corresponding current. The voltage dependence of the time constants is usually described by Gauss functions

$$c_b + c_a \exp\left(-\frac{(V_{Max} - V)^2}{\sigma^2}\right)$$

where the values of c_b , c_a , V_{Max} , σ depend similarly on the current and the variable.

2.3 Identifiability and model parameter estimation

Once the model structure is fixed, the next key step of the modelling process is parameter estimation the quality of which is crucial in later usability of the obtained model (see [25]). The identifiability properties of the system describe whether there is a theoretical possibility for the unique determination of system parameters from appropriate input-output measurements or not [26, 27]. The study and development of differential algebra methods, that are used for identifiability analysis, contributed to the better understanding of important system theoretic problems [28]. However, the analytic determination of identifiability properties may be a very difficult task beyond a certain level of system complexity.

Identifiability studies described in Thesis 2 are carried out with the aid of computer algebra packages (see eg. DAISY [29]). The parameter estimation of the G protein signaling model detailed in Thesis 1 was based on literature data, while the GFP (green fluorescent protein) based whole-cell patch

clamp electrophysiological recordings, which were used for the identification of the GnRH neuronal model detailed in Thesis 3, were completed in the Laboratory of the Department of Endocrine Neurobiology (Institute of Experimental Medicine Hungary). The parameter estimation of the G protein model with slow transmission was carried out with the Nelder-Mead simplex method [30], while the optimization procedure of the GnRH neuronal model was completed using the asynchronous parallel pattern search (APPS) algorithm [31], which can be efficiently implemented in parallel or grid environment.

In general, two basic measurement protocols are used for parameter estimation of neuronal models: the *voltage clamp (VC) protocol*, when the voltage is fixed and the transmembrane currents are measured, and the *current clamp protocol*, in which case an arbitrary value of injected current to the cell is fixed. In the case of current clamp, the time evolution of the voltage can be calculated as a function of the membrane currents

$$\frac{dV}{dt} = -\frac{1}{C}(\sum_i I_i) \quad (6)$$

where C is the membrane capacitance, and I_i denotes the currents with voltage dependent and independent conductance.

3 New scientific results

The main scientific contributions of the dissertation are summarized in the following theses.

Thesis 1 *ODE models of intracellular signaling pathways: rapid and slow transmission*

(Chapter 2, [P1], [P3])

A simplified dynamic model has been developed for the description of the dynamic behavior of G protein signaling, which takes into account the effect of slow (β -arrestin coupled) transmission, RGS mediated feedback regulation and ERK-phosphatase mediated feedback regulation. The parameters of the model have been determined via numerical optimization.

It has been shown, that the proposed reaction kinetic model of the system gives rise to an acceptable qualitative approximation of the G protein dependent and independent ERK activation dynamics that is in good agreement with the experimentally observed behavior.

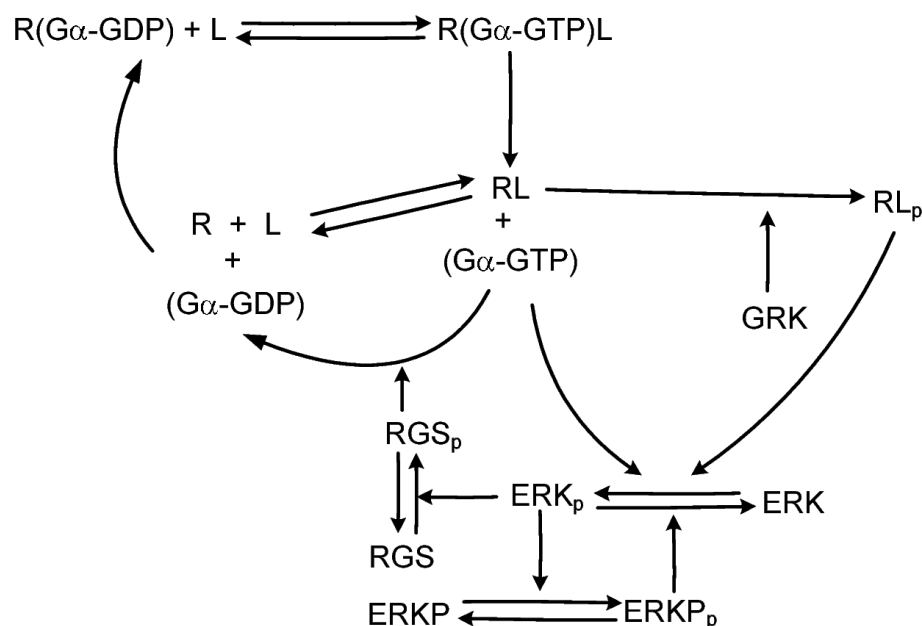

Figure 2: The reaction scheme of the kinetic model describing fast (G protein coupled) and slow (β -arrestin coupled) transmission)

Thesis 2 *Identifiability analysis of Hodgkin-Huxley type neuronal models*
(Chapter 3, [P6])

I analyzed the identifiability properties of a single Hodgkin-Huxley type voltage dependent ion channel model under voltage clamp circumstances. With formal identifiability analysis, it was shown that even in the simplest case when only the conductance and the steady state activation and inactivation parameters are to be estimated, no identifiable pair from the three can be chosen.

In addition, a possible novel identification method was proposed, which is based on the decomposition of the parameter estimation problem in two parts. The first part includes the estimation of the maximal conductance value and the activation/inactivation parameters from the values of steady state currents obtained from multiple voltage step traces. The use of steady state currents allows the estimation of the first parameter group independently of the other parameters. This parameter estimation problem results in a system of nonlinear algebraic equations, which was solved as an optimization problem.

The second part of the parameter estimation problem focuses on the parameters of the voltage dependent time constants, and is also formulated as an optimization problem. The parameter estimation method is demonstrated on in silico data, and the optimization process was carried out using the Nelder-Mead simplex algorithm in both cases.

The results of the analysis were used to formulate explicit criteria for the design of voltage clamp protocols.

Thesis 3 *Hodgkin-Huxley modelling of GnRH neuronal electrophysiology* (Chapter 4, [P2], [P4], [P5], [P6], [P7])

I performed studies including the application and analysis of Hodgkin-Huxley modelling methods.

A simple, one compartment Hodgkin-Huxley type electrophysiological model of GnRH neurons has been presented, that is able to reasonably reproduce the voltage clamp traces, and the most important qualitative features in the current clamp traces, such as baseline potential, depolarization amplitudes, sub-baseline hyperpolarization phenomenon and average firing frequency in response to excitatory current observed in GnRH neurons originating from hypothalamic slices.

The parameters of the model have been estimated using averaged VC traces of multiple GnRH neurons, and characteristic values of measured current clamp traces. Regarding the resulting parameter values, in most of the cases a good agreement with literature data was found.

Modification of model parameters makes the model capable of bursting, the effects of various parameters to burst length have been analyzed.

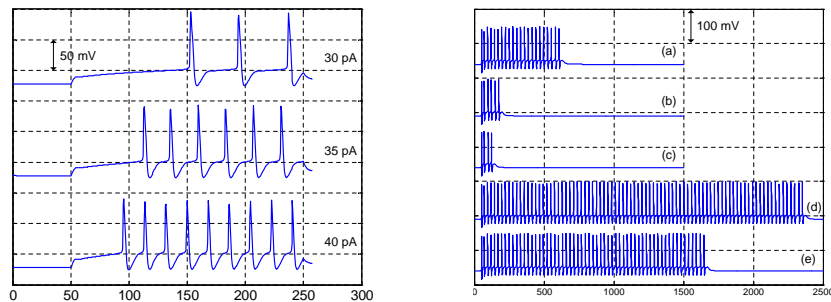

Figure 3: Simulated current clamp traces and various length bursts of the proposed model

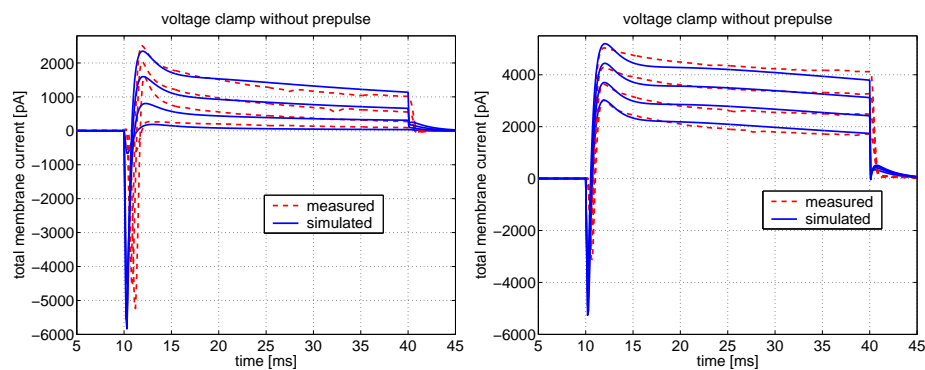

Figure 4: Measured and simulated voltage clamp traces

4 Publications related to the theses

Journal papers

- [P1] D. Cserecsik, K.M. Hangos and G.M. Nagy, "A simple reaction kinetic model of rapid (G protein dependent) and slow (β -Arrestin dependent) transmission," *Journal of Theoretical Biology*, vol 255(7), pp. 119-128, 2008, doi:10.1016/j.jtbi.2008.07.032 IF: 2.454 (**Thesis 1**)
- [P2] D. Cserecsik, I. Farkas, G. Szederkényi, E. Hrabovszky, Zs. Liposits and K.M. Hangos, "Hodgkin-Huxley type modelling and parameter estimation of GnRH neurons," *BioSystems*, vol 100, pp. 198-207, 2010, doi:10.1016/j.biosystems.2010.03.004 IF: 1.477 (**Thesis 3**)

Conference papers

- [P3] D. Cserecsik, K.M. Hangos, Gy.M. Nagy "Reaction kinetic models of rapid (g-protein dependent) and slow (beta-arrestin dependent) transmission," *Conference Abstract: Proc. IBRO International Workshop on Complex Neural Networks, "From synaptic transmission to seeing the brain in action,"* 24-26 January Debrecen, Hungary, 2008. (**Thesis 1**)
- [P4] D. Cserecsik, G. Szederkényi., K.M. Hangos and I. Farkas: "Parameter Estimation of Hodgkin-Huxley model of GnRH neurons," *Proceedings of the 9th International Phd. workshop: Young Generation Viewpoint*, October 1 - 3, Izola, Slovenia, 2008. (**Thesis 3**)
- [P5] D. Cserecsik, G. Szederkényi., K.M. Hangos and I. Farkas: "Model Synthesis and Identification of a One-Compartment Hodgkin-Huxley Type GnRH Neuron Model," *Frontiers in Systems Neuroscience. Conference Abstract: 12th Meeting of the Hungarian Neuroscience Society.* doi: 10.3389/conf.neuro.01.2009.04.106 (**Thesis 3**)
- [P6] D. Cserecsik, G. Szederkényi., K.M. Hangos and I. Farkas: "Dynamical Modeling and Identification of a GnRH neuron," *MCBMS'09 7th IFAC symposium on Modelling and Control in Biomedical Systems*, August 12-14, Aalborg, Denmark, 2009 (**Thesis 3**)
- [P7] D. Cserecsik, G. Szederkényi., K.M. Hangos and I. Farkas: "Model Synthesis and Identification of a Hodgkin-Huxley-Type GnRH neuron model," *ECC'09 European Control Conference*, August 23-26, Budapest, Hungary, 2009 (**Thesis 3**)
- [P8] D. Cserecsik, G. Szederkényi. and K.M. Hangos: "Identifiability of a Hodgkin-Huxley type ion channel under voltage step measurement conditions," *9th International Symposium on Dynamics and Control of Process Systems*, July 5-7, Leuven, Belgium, 2010 (**Thesis 2**)

Other Publications

- [E1] D. Csercsik, Cs. Fazekas. and K.M. Hangos, "Dynamical Analysis and Control of a Simple Nonlinear Limb Model," *Proceedings of the 3rd European Medical and Biological Engineering Conference*, Prague, Czech Republic , November 20 - 25, 2005.
- [E2] D. Csercsik, G. Szederkényi., "Cascade Control Methods of a Simple Nonlinear Limb Model," *Proceedings of the 7th International Ph.D. Workshop: Young Generation Viewpoint*, Hrubá Skála, Czech Republic, September 25 - 29, 2006.
- [E3] D. Csercsik, "Simple Dynamical Gamma-loop Models," *Proceedings of the 2nd Biomedical Engineering Conference of Young Biomedical Engineers and Researchers*, July 19 - 21, 2006 - Kladno, Czech Republic. *Lekar a Technika* 2:308-314, 2006.
- [E4] D. Csercsik and G. Szederkényi.: "Using graph-theoretic methods to find flat outputs," *Proceedings of the 8th International Phd. workshop: Young Generation Viewpoint*, September 16 - 20, Balatonfüred, Hungary, 2007.
- [E5] D. Csercsik, G. Szederkényi., and K.M. Hangos "Cascade Stabilization and Reference Tracking of a Simple Nonlinear Limb Model," *Proceedings of the 26th IASTED International Conference Modelling, Identification and Control*, February 12 - 14, - Innsbruck, Austria p. 369-374, 2007.
- [E6] Cs. Fazekas, D. Csercsik, G. Szederkényi., K.M. Hangos.: "Simulator for multi-scale musculoskeletal models with reflex circuits," *Proc. EUROSIM 2007* (B. Zupanic, R. Karba, S. Blazic), no. TH-1-P4-5, ISBN: 978-3-901608-32-2, September 9-13, Ljubljana, Slovenia, on CD, 2007.

5 Possible application area of results

In several disorders of reproductive system (which can be caused for eg. by polycystic ovary syndrome [32], long lasting usage of hormonal contraceptives, etc.), the hormonal cycle is disturbed, or it can even disappear. In these cases, to restore fertility, one possibility is the administration of the key hormone GnRH, or it's analogues to the patient. However, the oral administration of such medicines implies a slow imbibition, which can lead to unwanted side effects: After publication of a study that showed increased risk of ovarian cancer in women who used clomifene longer than 12 months the Committee on Safety of medicines in the UK has recommended that women should not take clomifene for longer than six months. One possible solution to this problem may be the application of portable GnRH pumps, which are able dose the medicines in a pulsatile way directly into the blood, achieving a time-concentration profile close to the physiological. However, the optimal usage of these devices would require a feedback, which takes the dynamics of the drug effects into account. Models like the one provided in Thesis 1, may help in the development and application of such devices.

In addition to the significance of arrestins and slow transmission in GnRH signaling, the importance of the slow transmission becomes evident nowadays in more and more fields of physiology and medicine. Health experts refer to diabetes mellitus as the disease of the future. According to the statistics of the World Health Organization (WHO) an increase of the adult diabetes population from 4% (in 2000, meaning 171 million people) to 5.4% (366 million worldwide) is predicted by the year 2030. Several new results point to the possibility, that β -arrestins play a central role in diabetes mellitus and insulin resistance [33, 34, 35].

The identifiability analysis, and parameter estimation method proposed in Thesis 2 can be used in the synthesis and identification of neuronal models. Furthermore these results provide bases for the future design of voltage clamp protocols in electrophysiological measurements dedicated to computational modelling.

The neuronal model of GnRH electrophysiology presented in Thesis 3 is intended to be later used in hierarchical models describing the hypothalamic GnRH pulse generator structure. A physiologically relevant model of the GnRH pulse generator would significantly enhance the usefulness of mathematical models corresponding to the reproductive neuroendocrine cycle. In addition such models can be applied in computational studies of neuronal interactions. A composite model of 2-3 neurons would be able to describe and

study many kinds of interactions, including for example endocannabinoid signaling.

References

- [1] F. Booger, F.J. Bruggeman, J.H.S. Hofmeyr, and H.V. Westerhoff. *Systems Biology: Philosophical Foundations*. Elsevier, Radarweg 29, PO Box 211, 1000 AE, Amsterdam, The Netherlands, 2007.
- [2] G. Weng, U.S. Bhalla, and R. Iyengar. Complexity in biological signaling systems. *Science*, 284:92–96, 1999.
- [3] P. Érdi. *Complexity Explained*. Springer, ISBN-13 978-3-540-35777-3 DOI 10.1007/978-3-540-35778-0, 2008.
- [4] R. Bertram, M. Egli, N. Toporikova, and M.E. Freeman. A mathematical model for the mating-induced prolactin rhythm of female rats. *American Journal of Physiology - Endocrinology and Metabolism*, 290:E573–E582, 2006.
- [5] J.A. Best, H.F. Nijhout, and M.C. Reed. Homeostatic mechanisms in dopamine synthesis and release: a mathematical model. *Theoretical Biology and Medical Modelling*, 6, 2009.
- [6] A.O. Komendantov, N.A. Trayanova, and J.G. Tasker. Somato-dendritic mechanisms underlying the electrophysiological properties of hypothalamic magnocellular neuroendocrine cells: A multicompartmental model study. *Journal of Computational Neuroscience*, 23:143–168, 2007. DOI 10.1007/s1-827-007-0024-z.
- [7] G. Leng and D. J. MacGregor. Mathematical modelling in neuroendocrinology. *Journal of Neuroendocrinology*, 20:713–718, 2008.
- [8] K.L. Pierce and R.J. Lefkowitz. Classical and new roles of β -arrestins in the regulation of G-protein-coupled receptors. *Nature Reviews Neuroscience*, 2:727–733, 2001.
- [9] J.M. Beaulieu, S. Marion, R.M. Rodriguiz, I.O. Medvedev, T.D. Sotnikova, V. Ghisi, W.C. Wetsel, R.J. Lefkowitz, R.R. Gainetdinov, and M.G. Caron. A β -arrestin 2 signaling complex mediates lithium action on behavior. *Cell*, 132:125–136, 2008.
- [10] R. J. Lefkowitz. Historical review: a brief history and personal retrospective of seven-transmembrane receptors. *Trends in Pharmacological Sciences*, 25:413–422, 2004.
- [11] N.J. Freedman and R.J. Lefkowitz. Desensitization of G protein-coupled receptors. *Recent Progress in Hormone Research*, 51:319–351, 1996.
- [12] K. A. DeFea, Z. D. Vaughn, E. M. O’Bryan, D. Nishijima, O. Dery, and N. W. Bunnett. The proliferative and antiapoptotic effects of substance P are facilitated by formation of a beta-arrestin-dependent scaffolding complex. *Proceedings of the National Academy of Sciences of the USA*, 98:11086–91, 2000.

- [13] L. M. Luttrell, F. L. Roudabush, E. W. Choy, W. E. Miller, and M. E. Field. Activation and targeting of extracellular signal-regulated kinases by beta-arrestin scaffolds. *Proceedings of the National Academy of Sciences of the USA*, 98:2449–2454, 2001.
- [14] J. M. Beaulieu, T. D. Sotinkova, S. Marion, R. J. Lefkowitz, R. R. Gainetdinov, and M. G. Caron. An Akt/ β -Arrestin 2/PP2A signaling complex mediates dopaminergic neurotransmission and behavior. *Cell*, 122:261–273, 2005.
- [15] J. M. Beaulieu, T. D. Sotinkova, W. D. Yao, L. Kockeritz, J. R. Woodgett, R.R. Gainetdinov, and M. G. Caron. Lithium antagonizes dopamine-dependent behaviors mediated by an AKT/glycogen synthase kinase 3 signaling cascade. *Proceedings of the National Academy of Sciences of the USA*, 101:5099–5114, 2004.
- [16] S. Galandrin, G. Oligny-Longpre, and M. Bouvier. The evasive nature of drug efficacy: implications for drug discovery. *Trends in Pharmacological Sciences*, 28:423–430, 2007.
- [17] M. Feinberg. On chemical kinetics of a certain class. *Archive for Rational Mechanics and Analysis*, 46:1–41, 2004.
- [18] G. Craciun and M. Feinberg. Multiple equilibria in complex chemical reaction networks: II The species-reaction graph. *Siam Journal of Applied Mathematics*, 66:1321–1338, 2006.
- [19] G. Craciun and M. Feinberg. Understanding bistability in complex enzyme-driven reaction networks. *Proceedings of the National Academy of Sciences of the United States of America*, 103:8697–8702, 2006.
- [20] R.C. Wilson, J.S. Kesner, J.M. Kaufmann, T. Uemura, T. Akema, and E. Knobil. Central electrophysiological correlates of pulsatile luteinizing hormone secretion in the rhesus monkey. *Neuroendocrinology*, 39:256–260, 1984.
- [21] A.E. Herbison, J.R. Pape, S.X. Simonian, M.J. Skynner, and J.A. Sim. Molecular and cellular properties of GnRH neurons revealed through transgenics in mouse. *Molecular and Cellular Endocrinology*, 185:185–194, 2001.
- [22] K.J. Suter, J.P. Wuarin, B.N. Smith, F.E. Dudek, and S.M. Moenter. Whole-cell recordings from preoptic/hypothalamic slices reveal burst firing in gonadotropin-releasing hormone neurons identified with green fluorescent protein in transgenic mice. *Endocrinology*, 141:3731–3736, 2000.
- [23] M.W. Hirsch, S. Smale, and R.L. Devaney. *Differential Equations, Dynamical Systems, and an Introduction to Chaos*. Academic Press, 84 Theobald’s Road London WC1X 8RR, UK, 2004.
- [24] E.M. Izhikevich. *Dynamical Systems in Neuroscience*. The MIT Press, 999 Riverview Drive Suite 208 Totowa New Jersey 07512, 2005.
- [25] L. Ljung. *System Identification - Theory for the User*. Prentice Hall, Englewood Cliffs, N.J., 1987.
- [26] E. Walter. *Identification of State Space Models*. Springer, Berlin, 1982.

- [27] E. Walter. *Identifiability of Parametric models*. Pergamon Press, Oxford, 1987.
- [28] M. Fliess and S. T. Glad. An algebraic approach to linear and nonlinear control. In H. L. Treutelman and J. C. Willeuis, editors, *Essays on control: Perspectives in the theory and its applications*, pages 223–267. Birkhauser, Boston, 1993.
- [29] M. P. Saccomani, S. Audoly, and L. D’Angio. Parameter identifiability of nonlinear systems: the role of initial conditions. *Automatica*, 39:619–632, 2003.
- [30] J.A. Nelder and R. Mead. A simplex method for function minimization. *The Computer Journal*, 7:308–313, 1965.
- [31] T.G. Kolda and V.J. Torczon. On the convergence of asynchronous parallel pattern search. *SIAM Journal of Optimization*, 14:939–964, 2004.
- [32] N. Bayram, M. van Wely, and F. van der Veen. Pulsatile gonadotrophin releasing hormone for ovulation induction in subfertility associated with polycystic ovary syndrome. *Cochrane Database Syst Rev*, 1, 2004.
- [33] J. Stockli and David E. James. Insulin action under arrestin. *Cell Metabolism*, 9:213–214, 2009.
- [34] J.T. Rodgers and P. Puigserver. Insulin resistance: β -arrestin development. *Cell Research*, 19:275–276, 2009.
- [35] B. Luan, J. Zhao, H. Wu, B. Duan, G. Shu, X. Wang, D. Li, W. Jia, J. Kang, and G. Pei. Deficiency of a β -arrestin-2 signal complex contributes to insulin resistance. *Nature*, 457:1146–1150, 2009.